

**HIWIN®**

# TORQUE MOTOR ROTARY TABLE

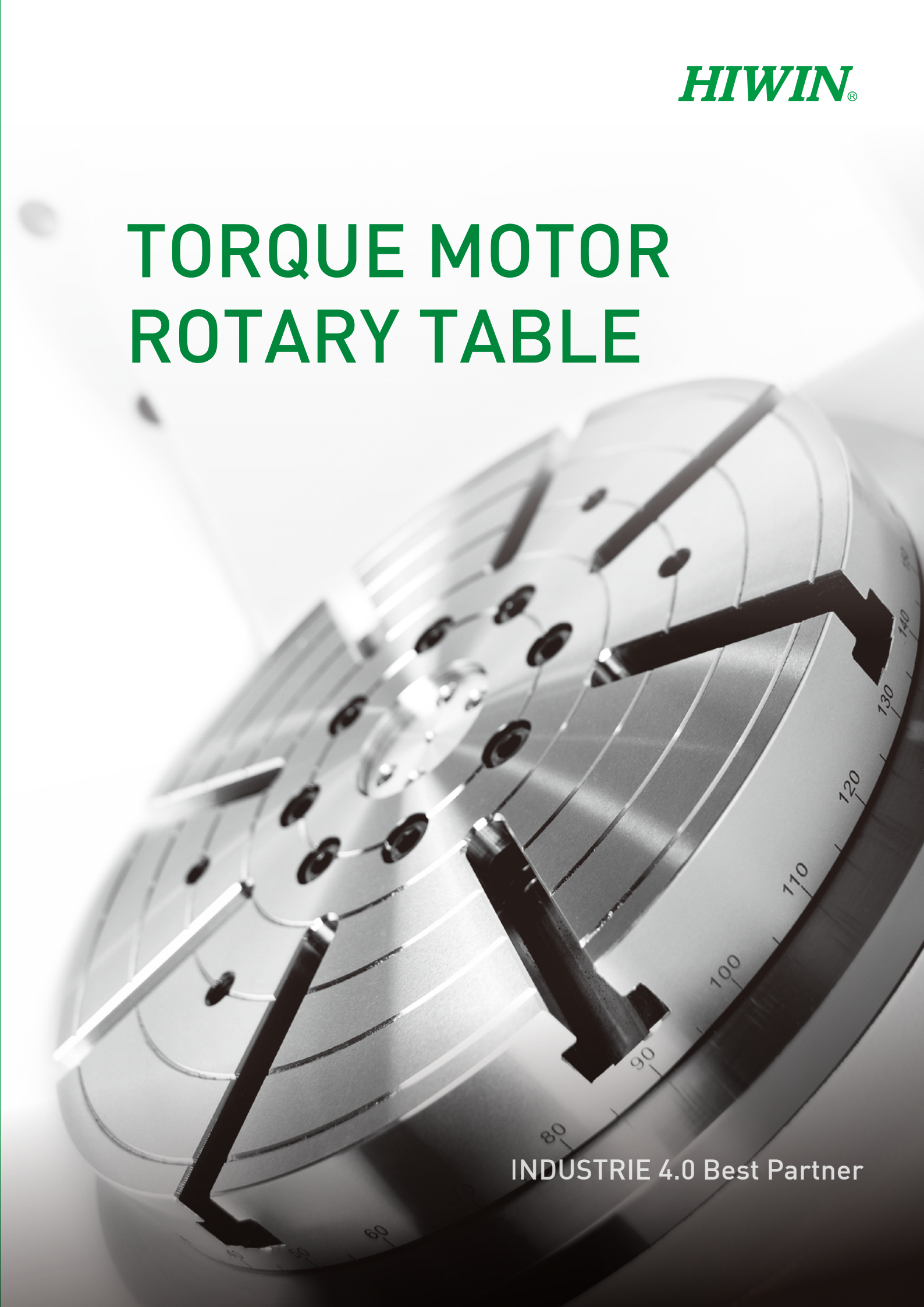

INDUSTRIE 4.0 Best Partner

# Product Description

## Torque Motor Rotary Table

HIWIN offers various types of Torque Motor Rotary tables.

Torque Motors with water-cooling systems can achieve both high acceleration and high torque. Integrate with high rigidity, high precision bearings, an absolute encoder and a powerful clamp makes HIWIN Rotary tables the high-performance solution.

## Torque Motor

HIWIN Rotary Tables feature torque motors with similar torque and higher acceleration compared to worm gears and roller cam systems.

Using a water-cooled torque motor not only reducing thermal deformation, but also increases working torque achieving high dynamic response and higher precision.

With zero backlash and zero wear, the torque motor can improve the reliability of the rotary table.



· Suitable for a variety of five-axis machining centers

### · Modular design

The structure is simple, with high reliability.

### · Easy replacement

Table supports a variety of applications. Table size and pattern can be adjusted according to customer's requirements.



· High speed  
· High rigidity  
· High positioning accuracy





### · High productivity

Excellent dynamic performance for increased efficiency.

### · Long service life

Simple structure, zero backlash, high stability.

# Torque Motor Rotary Table Inquiry Form

Product				
Model	<input type="checkbox"/> RCV	<input type="checkbox"/> RCH	<input type="checkbox"/> RAB	<input type="checkbox"/> RAS
Table Diameter	<input type="checkbox"/> 125 mm <input type="checkbox"/> 170 mm <input type="checkbox"/> 250 mm <input type="checkbox"/> 320 mm <input type="checkbox"/> Others _____ mm	<input type="checkbox"/> 200 mm <input type="checkbox"/> 400 mm <input type="checkbox"/> 600 mm <input type="checkbox"/> 800 mm <input type="checkbox"/> Others _____ mm	<input type="checkbox"/> 400 mm <input type="checkbox"/> 500 mm <input type="checkbox"/> 630 mm <input type="checkbox"/> 800 mm <input type="checkbox"/> Others _____ mm	<input type="checkbox"/> 170 mm <input type="checkbox"/> 200 mm <input type="checkbox"/> 250 mm <input type="checkbox"/> 320 mm <input type="checkbox"/> 650 mm <input type="checkbox"/> Others _____ mm
Controller ※ 1	<input type="checkbox"/> HEIDENHAIN <input type="checkbox"/> SIEMENS <input type="checkbox"/> MITSUBISHI <input type="checkbox"/> FANUC <input type="checkbox"/> Others _____	<input type="checkbox"/> HEIDENHAIN <input type="checkbox"/> SIEMENS <input type="checkbox"/> MITSUBISHI <input type="checkbox"/> FANUC <input type="checkbox"/> Others _____	<input type="checkbox"/> HEIDENHAIN <input type="checkbox"/> SIEMENS <input type="checkbox"/> MITSUBISHI <input type="checkbox"/> FANUC <input type="checkbox"/> Others _____	<input type="checkbox"/> HEIDENHAIN <input type="checkbox"/> SIEMENS <input type="checkbox"/> MITSUBISHI <input type="checkbox"/> FANUC <input type="checkbox"/> Others _____
Option	<input type="checkbox"/> Tailstock <input type="checkbox"/> Booster Regulator <input type="checkbox"/> Power Cable ____ m ※ 2 <input type="checkbox"/> Encoder Cable ____ m ※ 2 <input type="checkbox"/> None	<input type="checkbox"/> Booster Regulator <input type="checkbox"/> Power Cable ____ m ※ 2 <input type="checkbox"/> Encoder Cable ____ m ※ 2 <input type="checkbox"/> None	<input type="checkbox"/> Booster Regulator <input type="checkbox"/> Power Cable ____ m ※ 2 <input type="checkbox"/> Encoder Cable ____ m ※ 2 <input type="checkbox"/> None	<input type="checkbox"/> Booster Regulator <input type="checkbox"/> Power Cable ____ m ※ 2 <input type="checkbox"/> Encoder Cable ____ m ※ 2 <input type="checkbox"/> None
Other	(1) Speed _____ (2) Torque _____ (3) IP Class _____ (4) Other brands used _____ (5) Application _____			
Sales Person :			Customer :	

※ 1: Selecting controller for torque motor rotary table, please see page 15 {Table 3,4,5}.

※ 2: Cable length with 2,3,6,9,11 meters can be selected.

# Torque Motor Rotary Table

## RAB Series



### FEATURES

- Rigid and symmetrical mechanical design.
- High acceleration, high torque, high precision and zero backlash torque motor.
- Powerful built-in clamping system.
- Both rotary and tilting axis use large bore diameter, high precision ,high rigidity bearing.

Spec / Model	Unit	RAB-400		RAB-500		RAB-630		RAB-800	
Table Diameter	mm	400		500		630		800	
Center Height	mm	300		350		250		325	
Table Height	-	300		300		150		225	
T-Slot Width	mm	14H8							
Axis	-	Rotary	Tilting ± 120°	Rotary	Tilting ± 120°	Rotary	Tilting ± 120°	Rotary	Tilting ± 120°
Torque Motor	-	TMRWA5	TMRWAA	TMRWA7	TMRWAF-SB	TMRWA7	TMRWAF-SB	TMRWDF-PD-U10	
Max. Revolutions per Minute	r.p.m	90	60	100	60	100	60	90	60
Continuous Torque	N-m	430	860	600	1290	600	1290*2	2200	2200*2
Peak Torque	N-m	810	1600	1100	2400	1100	2400*2	3900	3900*2
Clamping Type	-	Pneumatic (6 bar)							
Clamping Torque	N-m	2400	3240	2400	2400*2	2400	2400*2	4200	4200*2
Net Weight	kg	800		1000		1200		2200	
Max. Load Capacity	kg	350		850		850		1200	

※ 1: All models listed in the table are standard specification. If any special requirement is needed, please contact HIWIN.  
 ※ 2: Max. revolution per minute and continuous torque will differ according to voltage of power supply.

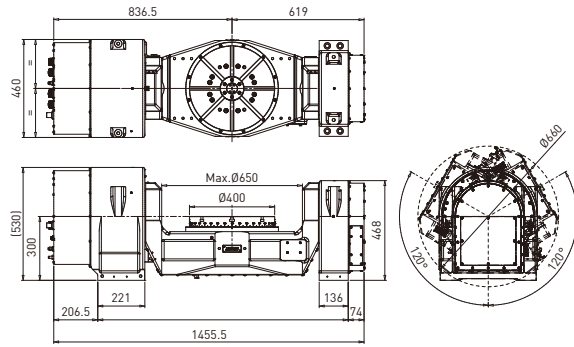

RAB-400

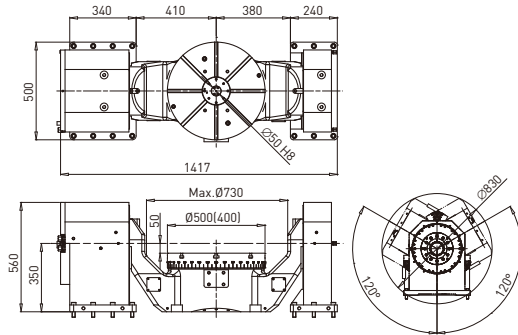

RAB-500

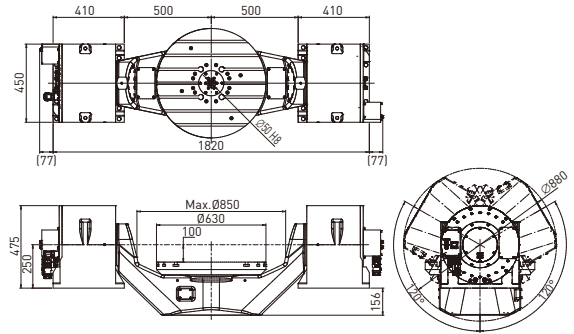

RAB-630

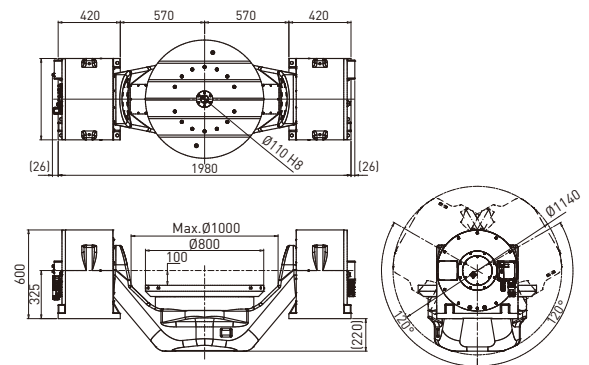

RAB-800

# Torque Motor Rotary Table

## RAS Series



### FEATURES

- High acceleration, high torque, high precision and zero backlash torque motor.
- Powerful built-in clamping system.
- Both rotary and tilting axis use large bore diameter, high precision, high rigidity bearing.

Spec / Model	Unit	RAS-170		RAS-200		RAS-200-SP		RAS-250		RAS-320		RAS-650	
Table Diameter	mm	170		200		200		250		320		650	
Center Height	mm	260		280		280		185		235		300	
Table Height	-	280		280		280		185		205		250	
T-Slot Width	mm	14H8		12H8				14H8					
Axis	-	Rotary	Tilting ± 120°	Rotary	Tilting ± 120°	Rotary	Tilting ± 120°	Rotary	Tilting ± 120°	Rotary	Tilting ± 120°	Rotary	Tilting ± 120°
Torque Motor	-	TMRW23	TMRW4A	TMRW43	TMRW4A	TMRW43-SB	TMRW4A	TMRW73	TMRW77	TMRW4A	TMRWAL-SB	TMRWA7	TMRWDF
Max. Revolutions per Minute	r.p.m	200	60	200	60	2000	100	200	80	150	60	100	60
Continuous Torque	N-m	35	205	63.5	205	27.9	205	145	335	205	1900	600	2000
Peak Torque	N-m	66.5	390	120	390	52.7	390	275	640	390	3360	1100	3600
Clamping Type	-	Pneumatic (6 bar)											
Clamping Torque	N-m	250	840	300	840	300	840	600	1500	840	2400	2400	4200
Net Weight	kg	250		260				300		660		1300	
Max. Load Capacity	kg	30		50				85		200		300	

※ 1: All models listed in the table are standard specification. If any special requirement is needed, please contact HIWIN.

※ 2: Max. revolution per minute and continuous torque will differ according to voltage of power supply.



RAS-170

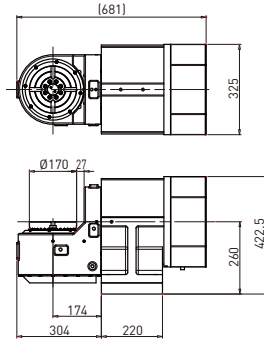
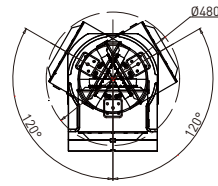

RAS-200 (RAS-200-SP)

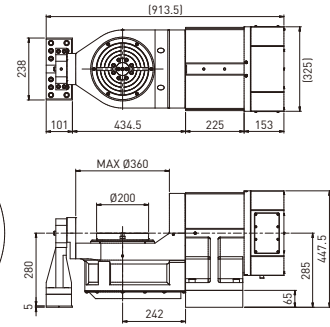
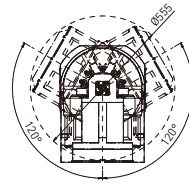

RAS-250

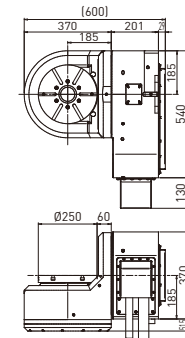
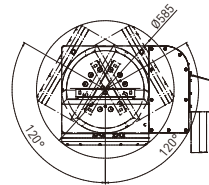

RAS-320

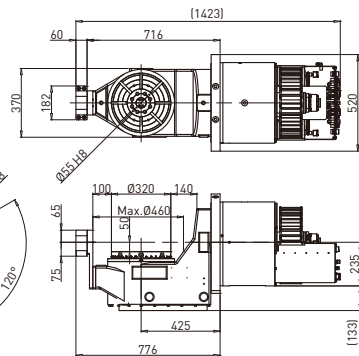
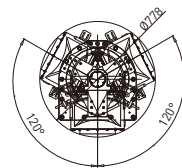

RAS-650

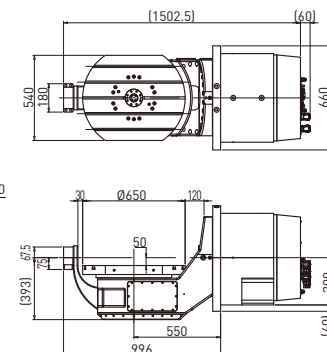
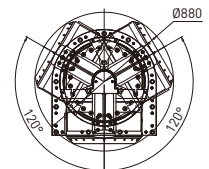

# Torque Motor Rotary Table

## RCV Series



### FEATURES

- High acceleration, high torque, high precision and zero backlash torque motor.
- High precision, high rigidity bearing.
- Powerful built-in clamping system.
- Widely used in machining center spindle tilting axis and working table.

Spec / Model	Unit	RCV-125	RCV-170	RCV-250	RCV-320
Table Diameter	mm	125	170	250	320
Center Height	mm	100	135	160	220
Center bore diameter	mm	Ø30x26L	Ø60	Ø60	Ø60
T-Slot Width	mm	12H8	12H8	12H8	14H8
Torque Motor	-	TMRW15	TMRW45	TMRW47	TMRWA5
Max. Revolutions per Minute	r.p.m	400	200	140	90
Continuous Torque	N-m	31.3	106	148	430
Peak Torque	N-m	59.4	203	280	810
Clamping Type	-	Pneumatic (6 bar)			
Clamping Torque	N-m	100	300	600	900
Net Weight	kg	30	95	150	320
Max. Load Capacity	kg	20	50	160	250

※1: All models listed in the table are standard specification. If any special requirement is needed, please contact HIWIN.

※2: Max. revolution per minute and continuous torque will differ according to voltage of power supply.



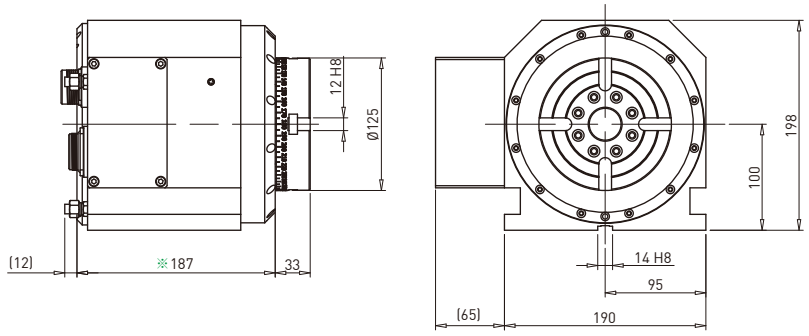

RCV-125

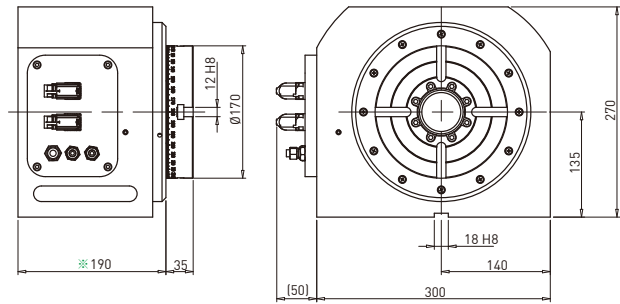

RCV-170

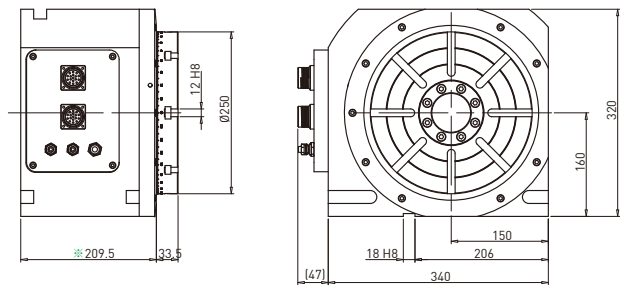

RCV-250

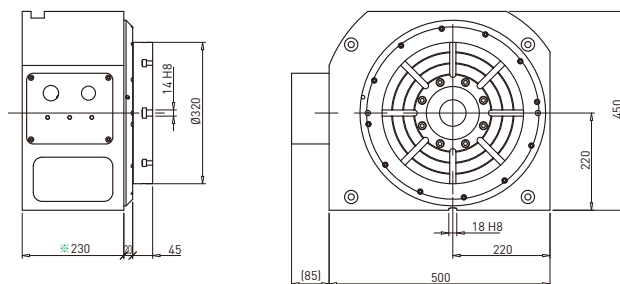

RCV-320

※ Product size varies from encoder selection.

# Torque Motor Rotary Table

## RCH Series



### FEATURES

- High acceleration, high torque, high precision and zero backlash torque motor.
- Large bore diameter, high precision, high rigidity bearing.
- Powerful built-in clamping system.

Spec / Model	Unit	RCH-200-SP	RCH-200	RCH-400	RCH-600	RCH-800
Table Diameter	mm	200	200	400	600	800
Torque Motor	-	TMRW43-SB	TMRW43	TMRW7A	TMRWAF-SB	TMRWDF
Max. Revolutions per Minute	r.p.m	2000	280	115	100	80
Continuous Torque	N-m	27.9	63.5	480	1290	2000
Peak Torque	N-m	52.7	120	910	2400	3600
Clamping Type	-	Pneumatic (6 bar)		Hydraulic Pressure (70 bar)		Pneumatic (6 bar)
Clamping Torque	N-m	600	600	2000	3200	4200
Net Weight	kg	85	85	190	430	750
Max. Load Capacity	kg	50	100	500	850	1800

※1: All models listed in the table are standard specification. If any special requirement is needed, please contact HIWIN.

※2: Max. revolution per minute and continuous torque will differ according to voltage of power supply.



RCH-200

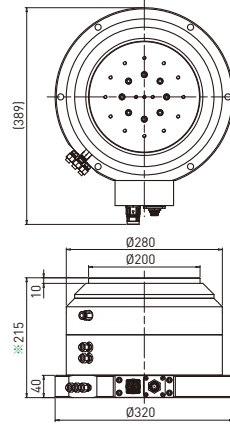

RCH-400

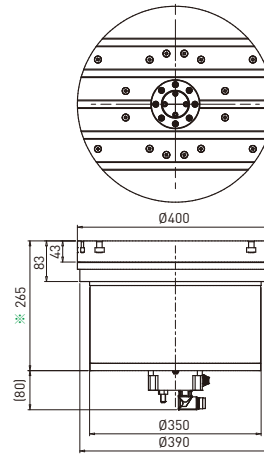

RCH-600

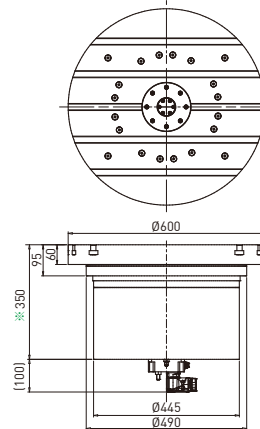

RCH-800

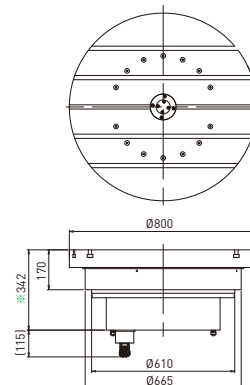

※ Product size varies from encoder selection.

## Torque Motor Rotary Table Connector Specifications

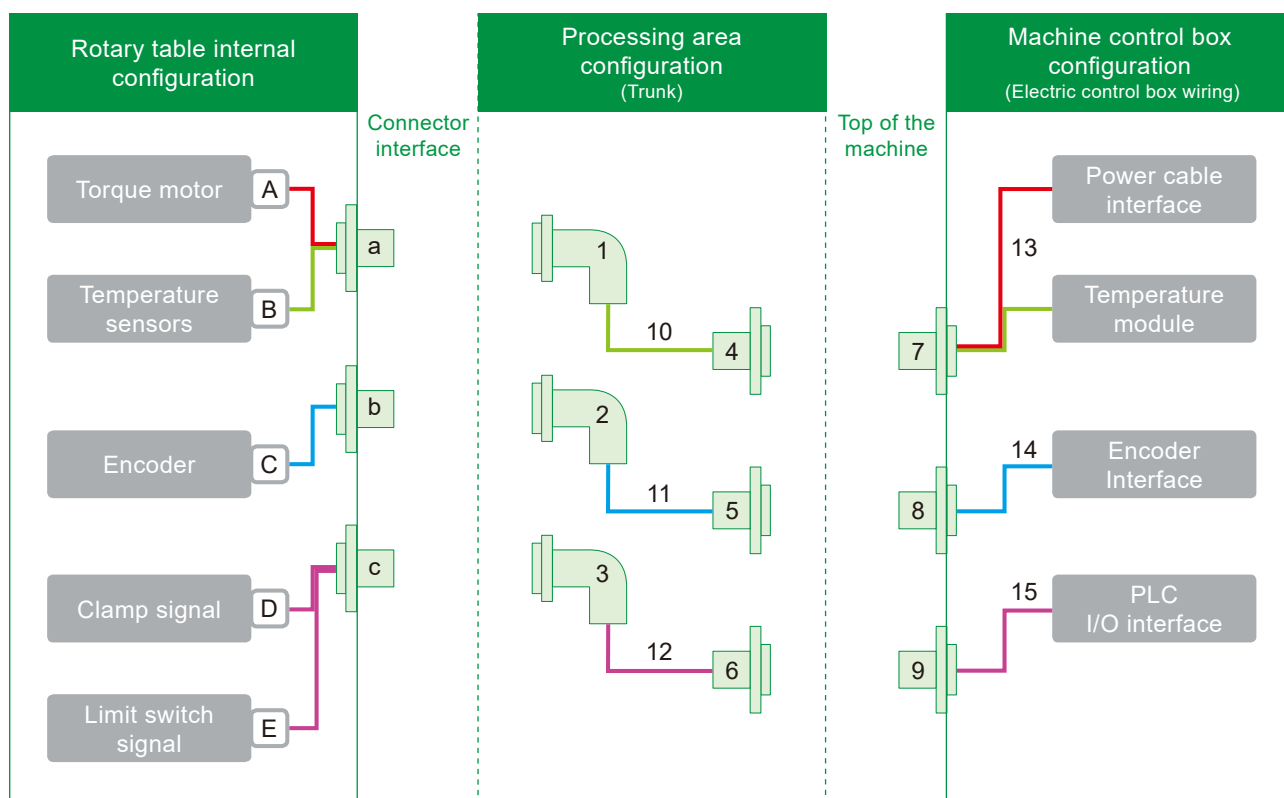

- ※ 1: The internal configuration may differ in different models.
- ※ 2: Dashed lines can be omitted according to different machine.
- ※ 3: 1 ~ 15 are the optional accessories, please refer to the accessories {Table 1,2}.
- ※ 4: If connector is in working area, please select military type connector.







## Torque Motor Rotary Table Connector Table

Table 1: Rotary table connector

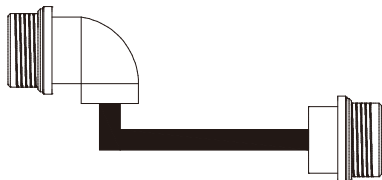
No.	Name	Model	Description
(1) (2) (3)	Straight military Connector	MS3106A-20-4S \ MS3106A-16S-1S MS3106A-20-29S \ MS3106A-18-10S MS3106A-22-22S \ MS3106A-22-23S	
	90 degree military Connector	MS3108A-20-4S \ MS3108A-16S-1S MS3108A-20-29S \ MS3108A-18-10S MS3108A-22-22S \ MS3108A-22-23S	
	European Connector	CSTA265FR01450001000 CSTA263FR42440001000 BSTA082FR06590235000 BSTA896FR0986202A000 ASTA046FR0187050A000	
(4) (5) (6)	Straight military Connector	MS3106A-20-4S \ MS3106A-16S-1P MS3106A-20-29P \ MS3106A-18-10P MS3106A-22-22P \ MS3106A-22-23P	
(7) (8) (9)	Flange military Connector	MS3102A-20S-4S \ MS3102A-16S-1S MS3102A-20-29S \ MS3102A-18-10S MS3102A-22-2S \ MS3102A-22-23S	

# Cable Selection For Torque Motor Rotary Table

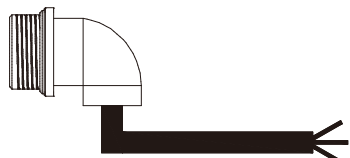
Table 2 : Cable Selection Table

Item No.	Item	Model	Schematic
(10) (11) (12)	Junction cable	□□ -0MS- □ -0MP- □□ - □□□ - □□	 Type: MS3106(Female) → MS3106(Male)
		□□ -9MS- □ -0MP- □□ - □□□ - □□	 Type: MS3106(Female) → MS3106(Male)
		□□ -0ES- □ -0MP- □□ - □□□ - □□	 Type: Europe connector(Female) → MS3106(Male)
(13) (14) (15)	Electric box cable	□□ -0MS- □ -00P- □□ - □□□ - □□	 Type: MS3102(Female) → Discrete wiring(Europe insulated cord)
		□□ -0MS- □ -00P- □□ - □□□ - □□	 Type: MS3106(Female) → Discrete wiring(Europe insulated cord)
		□□ -9MS- □ -00P- □□ - □□□ - □□	 Type: MS3108(Female) → Discrete wiring(Europe insulated cord)
		□□ -0ES- □ -00P- □□ - □□□ - □□	 Type: Europe connector(Female) → Discrete wiring(Europe insulated cord)

※ Note1: Provide selective one-piece cable connector including (power cable, encoder cable, clamping signal, pneumatic tube).

※ Note2: Provide optional HEIDENHAIN encoder signal cable.

※ Note3: Please refer to appendix below for model selection.

# Cable Selection For Torque Motor Rotary Table

## Cable Selection Table Appendix

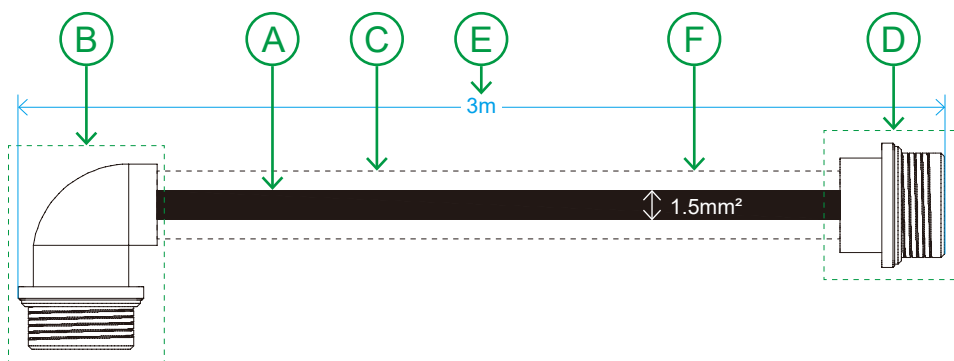
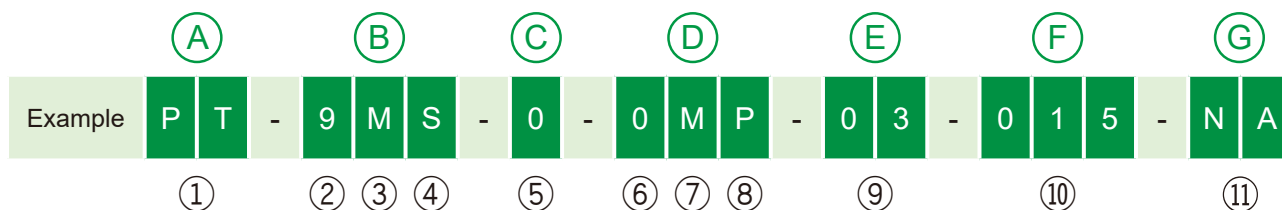

① Wire		② Direction		③ Connector type		④ Pin type		⑤ Protective material		⑥ Direction		⑦ Connector type		⑧ Pin type		⑨ Length		⑩ Wire diameter		⑪ Note													
PT		-		9		M		S		-		0		-		0		M		P		-		03		-		015		-		NA	
PC	Power cable	0	Straight	M	Military type	P	Male pin	N	Nylon tube(NL206)	0	Straight	M	Military type	P	Male pin	2	2 Meters	007	0.75 mm²	NA	None												
PT	Power cable with temperture sensor	9	90 degree	E	Europe type	S	Female pin	0	PVC pipe(PT706)	9	90 degree	E	Europe type	S	Female pin	3	3 Meters	015	1.5mm²	00	SMC40												
ST	Clamping signal with temperture sensor			H	Heavy duty type			2	Stainless steel wire(NK206)			H	Heavy duty type			6	6 Meters	025	2.5mm²	01	SME125												
EC	Encoder signal cable							7	None			N	Mitsubish type			9	9 Meters	040	4.0mm²	02	M12												
ET	Encoder signal cable with temperture sensor											F	Fanuc type			11	11 Meters	060	6.0mm²	03	M23												
TC	Temperture sensor cable											C	Siemens type					100	10mm²	04	623												
OT	Other											S	Synyc type					000	Signal cable	05	617												
																				0	Discrete wiring			06	A9777								
																						07	14S-2										
																						08	D-SUB										

※ Note: Detail selection please see page 13 {Table 2}.

## Selection Table For Torque Motor Rotary Table

Table 3 : Controller Selection For Rotary Table

Controller \ Type	RAB series	RAS series	RCV series	RCH series
FANUC	■ + ◎	■ + ◎	■ + ◎	■ + ◎
MITSUBISHI	○	○	○	○
SIEMENS	○	○	○	○
HEIDENHAIN	○	○	○	○
NUM	○	○	○	○
Syntec	▲	▲	○	○
Lynuc	○	○	○	○
Huazhong CNC	○	○	○	○
GSK	○	○	○	○

- ※ Note: ○ Means the controller supports the communication of the rotary table.  
 ▲ Means partially support, further information please contact HIWIN.  
 ■ Indicates that it requires to apply for the motor parameters from the original controller supplier.  
 ◎ Indicates that it requires to apply for motor pole detection function from the original controller supplier.

Table 4 : Encoder Selection For Rotary Table

Encoder \ Type	RAB series	RAS series	RCV series	RCH series
HEIDENHAIN	○	○	○	○
RENISHAW	-	-	○	○
NIKON	-	-	○	○

- ※ Note: For encoder accuracy and repeatability, please refer to the encoder supplier technical data.  
 ○ Indicates that the series of Rotary Table can be compatible with this encoder manufacturer.  
 - Indicates that the series of Rotary Table is not compatible with this encoder manufacturer.

Table 5 : Controller Selection For Encoder

Controller \ Encoder	HEIDENHAIN	RENISHAW	NIKON
FANUC	○	○	X
MITSUBISHI	○	○	X
SIEMENS	○	○	X
HEIDENHAIN	○	X	X
NUM	○	○	X
Syntec	○	○	○
Lynuc	○	○	X
Huazhong CNC	○	○	X
GSK	○	X	X

- ※ Note: ○ Indicates that this controller is compatible with the encoder.  
 X Indicates that the controller is not compatible with the encoder.

*Authorized System Integrator in India*

## SINUTECH MACHINE TOOLS

ALL TYPES OF CNC MACHINES RETROFITMENT  
& SERVICES

Shop No.A-03, Ellora Shopee, Plot No. 2 & 3, Sector  
01, Indrayani Nagar, Bhosari, Pune - 411039

9325501977 / 7720006159

sinutech.systems@gmail.com | sinutech@yahoo.com

www.sinutech.in

### Subsidiaries / Research Center

HIWIN GmbH  
OFFENBURG, GERMANY  
www.hiwin.de  
www.hiwin.eu  
info@hiwin.de

HIWIN JAPAN  
KOBE · TOKYO · NAGOYA · NAGANO ·  
TOHOKU · SHIZUOKA · HOKURIKU ·  
HIROSHIMA · FUKUOKA · KUMAMOTO,  
JAPAN  
www.hiwin.co.jp  
info@hiwin.co.jp

HIWIN USA  
CHICAGO, U.S.A.  
www.hiwin.com  
info@hiwin.com

HIWIN Srl  
BRUGHERIO, ITALY  
www.hiwin.it  
info@hiwin.it

HIWIN Schweiz GmbH  
JONA, SWITZERLAND  
www.hiwin.ch  
info@hiwin.ch

HIWIN s.r.o.  
BRNO, CZECH REPUBLIC  
www.hiwin.cz  
info@hiwin.cz

HIWIN SINGAPORE  
SINGAPORE  
www.hiwin.sg  
info@hiwin.sg

HIWIN KOREA  
SUWON · MASAN, KOREA  
www.hiwin.kr  
info@hiwin.kr

HIWIN CHINA  
SUZHOU, CHINA  
www.hiwin.cn  
info@hiwin.cn

Mega-Fabs Motion  
Systems, Ltd.  
HAIFA, ISRAEL  
www.mega-fabs.com  
info@mega-fabs.com

# HIWIN®

### HIWIN TECHNOLOGIES CORP.

No. 7, Jingke Road,  
Taichung Precision Machinery Park,  
Taichung 40852, Taiwan  
Tel: +886-4-23594510  
Fax: +886-4-23594420  
www.hiwin.tw  
business@hiwin.tw

- HIWIN is a registered trademark of HIWIN Technologies Corp. For your protection, avoid buying counterfeit products from unknown sources.
- Actual products may differ from specifications and photos provided in this catalog. These differences may be the result of various factors including product improvements.
- HIWIN will not sell or export products or processes restricted under the "Foreign Trade Act" or related regulations. Export of restricted products should be approved by proper authorities in accordance with relevant laws and shall not be used to manufacture or develop nuclear, biochemical, missiles or other weapons.
- HIWIN website for patented product directory: [http://www.hiwin.tw/Products/Products\\_patents.aspx](http://www.hiwin.tw/Products/Products_patents.aspx)

The specifications in this catalog are subject to change without notification.

Copyright © HIWIN Technologies Corp.

©2019 FORM I99DE05-1903 (PRINTED IN TAIWAN)